



Standard Test Method for Specific Optical Density of Smoke Generated by Solid Materials¹

This standard is issued under the fixed designation E662; the number immediately following the designation indicates the year of original adoption or, in the case of revision, the year of last revision. A number in parentheses indicates the year of last reapproval. A superscript epsilon (ϵ) indicates an editorial change since the last revision or reapproval.

This standard has been approved for use by agencies of the U.S. Department of Defense.

1. Scope*

1.1 This fire-test-response standard covers determination of the specific optical density of smoke generated by solid materials and assemblies mounted in the vertical position in thicknesses up to and including 1 in. (25.4 mm).

1.2 Measurement is made of the attenuation of a light beam by smoke (suspended solid or liquid particles) accumulating within a closed chamber due to nonflaming pyrolytic decomposition and flaming combustion.

1.3 Results are expressed in terms of specific optical density which is derived from a geometrical factor and the measured optical density, a measurement characteristic of the concentration of smoke.

1.4 The values stated in inch-pound units are to be regarded as standard. The values given in parentheses are mathematical conversions to SI units that are provided for information only and are not considered standard.

1.5 *This standard measures and describes the response of materials, products, or assemblies to heat and flame under controlled conditions, but does not by itself incorporate all factors required for fire hazard or fire risk assessment of the materials, products or assemblies under actual fire conditions.*

1.6 *This standard does not purport to address all of the safety concerns, if any, associated with its use. It is the responsibility of the user of this standard to establish appropriate safety and health practices and determine the applicability of regulatory limitations prior to use.*

2. Referenced Documents

2.1 *ASTM Standards:*²

¹ This test method is under the jurisdiction of ASTM Committee E05 on Fire Standards and is the direct responsibility of Subcommittee E05.21 on Smoke and Combustion Products.

Current edition approved Feb. 1, 2017. Published March 2017. Originally approved in 1979. Last previous edition approved in 2015 as E662 – 15a. DOI: 10.1520/E0662-17.

² For referenced ASTM standards, visit the ASTM website, www.astm.org, or contact ASTM Customer Service at service@astm.org. For *Annual Book of ASTM Standards* volume information, refer to the standard's Document Summary page on the ASTM website.

[D2843 Test Method for Density of Smoke from the Burning or Decomposition of Plastics](#)
[E176 Terminology of Fire Standards](#)
[E662 Test Method for Specific Optical Density of Smoke Generated by Solid Materials](#)

3. Terminology

3.1 *Definitions*—For definitions of terms found in this test method refer to Terminology E176.

4. Summary of Test Method

4.1 This test method employs an electrically heated radiant-energy source mounted within an insulated ceramic tube and positioned so as to produce an irradiance level of 2.2 Btu/s-ft² (2.5 W/cm²) averaged over the central 1.5-in. (38.1-mm) diameter area of a vertically mounted specimen facing the radiant heater. The nominal 3 by 3-in. (76.2 by 76.2-mm) specimen is mounted within a holder which exposes an area measuring 2⁹/₁₆ by 2⁹/₁₆ in. (65.1 by 65.1 mm). The holder is able to accommodate specimens up to 1 in. (25.4 mm) thick. This exposure provides the nonflaming condition of the test.

4.2 For the flaming condition, a six-tube burner is used to apply a row of equidistant flamelets across the lower edge of the exposed specimen area and into the specimen holder trough. This application of flame in addition to the specified irradiance level from the heating element constitutes the flaming combustion exposure.

4.3 The test specimens are exposed to the flaming and nonflaming conditions within a closed chamber. A photometric system with a vertical light path is used to measure the varying light transmission as smoke accumulates. The light transmittance measurements are used to calculate specific optical density of the smoke generated during the time period to reach the maximum value.³

5. Significance and Use

5.1 This test method provides a means for determining the specific optical density of the smoke generated by specimens of

³ Additional parameters, such as the maximum rate of smoke accumulation, time to a fixed optical density level, or a smoke obscuration index provide potentially useful information. See [Appendix X1](#).

*A Summary of Changes section appears at the end of this standard

materials and assemblies under the specified exposure conditions. Values determined by this test are specific to the specimen or assembly in the form and thickness tested and are not to be considered inherent fundamental properties of the material tested. Thus, it is likely that closely repeatable or reproducible experimental results are not to be expected from tests of a given material when specimen thickness, density, or other variables are involved.

5.2 The photometric scale used to measure smoke by this test method is similar to the optical density scale for human vision. However, physiological aspects associated with vision are not measured by this test method. Correlation with measurements by other test methods has not been established.⁴

5.3 At the present time no basis is provided for predicting the density of smoke generated by the materials upon exposure to heat and flame under other fire conditions.

5.4 The test method is of a complex nature and the data obtained are sensitive to variations which in other test methods might be considered to be insignificant (see Section 6). A precision statement based on the results of a roundrobin test by a prior draft version of this test method is given in 14.1

5.5 In this procedure, the specimens are subjected to one or more specific sets of laboratory test conditions. If different test conditions are substituted or the end-use conditions are changed, it is not always possible by or from this test method to predict changes in the fire-test-response characteristics measured. Therefore, the results are valid only for the fire test exposure conditions described in this procedure.

6. Limitations

6.1 If during the test of one or more of the three replicate samples there occurs such unusual behavior as (1) the specimen falling out of the holder, (2) melted material overflowing the sample holder trough, (3) self-ignition in the pyrolysis mode, (4) extinguishment of the flame tiptlets (even for a short period of time), or (5) a specimen being displaced from the zone of controlled irradiance, then an additional three samples of the identical preconditioned materials shall be tested in the test mode in which the unusual behavior occurred. Data obtained from the improper tests noted above shall not be incorporated in the averaged data but the occurrence shall be reported. The test method is not suitable if more than three of the six replicates tested show these characteristics.

6.2 The test method has proven sensitive to small variations in sample geometry, surface orientation, thickness (either overall or individual layer), weight, and composition. It is, therefore, critical that the replicate samples be cut, sawed, or blanked to identical sample areas, 3 by 3, +0, -0.03 in. (76.2 by 76.2, +0, -0.8 mm), and that records be kept of the respective weights with the individual test data. It is feasible that evaluation of the obtained data together with the individual

weights will assist in assessing the reasons for any observed variability in measurements. Preselection of samples with identical thickness or weight, or both, are potential methods to reduce the variability but are likely to not be truly indicative of the actual variability to be expected from the material as normally supplied.

6.3 The results of the test apply only to the thickness of the specimen as tested. There is no common mathematical formula to calculate the specific optical density of one thickness of a material when the specific optical density of another thickness of the same material is known.

6.4 The test method is sensitive to small variations of the position of the specimen and radiometer relative to the radiant heat source.

6.5 It is critical to clean the test chamber, and to remove accumulated residues from the walls when changing from one test material to another, to ensure that chemical or physical recombination with the effluents or residues produced does not affect the data obtained. Even when testing the same material, excessive accumulations of residue shall not be permitted to build up since ruggedness tests have indicated that such accumulations serve as additional insulators tending to reduce normally expected condensation of the aerosol, thereby raising the measured specific optical density.

6.6 With resilient samples, take extreme care to ensure that each replicate sample in its aluminum foil wrapper is installed so that each protrudes identically through the front sample holder opening. Unequal protrusion will subject the samples to different effective irradiances and to slightly different ignition exposures. Excessive protrusion of specimens has the potential to cause drips or for the specimen to sag onto the burner, clogging the flame jets and thereby invalidating the test.

6.7 The measurements obtained have also proven sensitive to small differences in conditioning (see Section 9). Many materials such as carpeting and thick sections of wood, plastics, or plywood require long periods to attain equilibrium (constant weight) even in a forced-draft humidification chamber.

7. Apparatus

7.1 Fig. 1 shows examples of the test apparatus, with a detailed description contained in the remainder of Section 7 and in Annex A2. The apparatus shall include the following:

7.1.1 *Test Chamber*—As shown in Fig. 1, the test chamber shall be fabricated from laminated panels⁵ to provide inside dimensions of 36 by 24 by 36 ± 1/8 in. (914 by 610 by 914 ± 3 mm) for width, depth, and height, respectively. The interior surfaces shall consist of porcelain enameled metal, or other coated metal, which shall be resistant to chemical attack and corrosion, and suitable for periodic cleaning. Sealed windows shall be provided to accommodate a vertical photometric system. All other chamber penetrations shall be sealed. When all openings are closed, the chamber shall be capable of

⁴ Other test methods for measuring smoke available at the time of the publications referenced have been reviewed and summarized in “The Control of Smoke in Building Fires—A State of the Art Review.” *Materials Research and Standards*, Vol 42, April 1971, pp. 16–23 and “A Report on Smoke Test Methods,” *ASTM Standardization News*, August 1976, pp. 18–26.

⁵ Commercially available panels of porcelain-enameled steel (interior surface) permanently laminated to an asbestos-magnesia core and backed with galvanized steel (exterior surface), total thickness 3/16 in. (9.6 mm), have been found suitable.

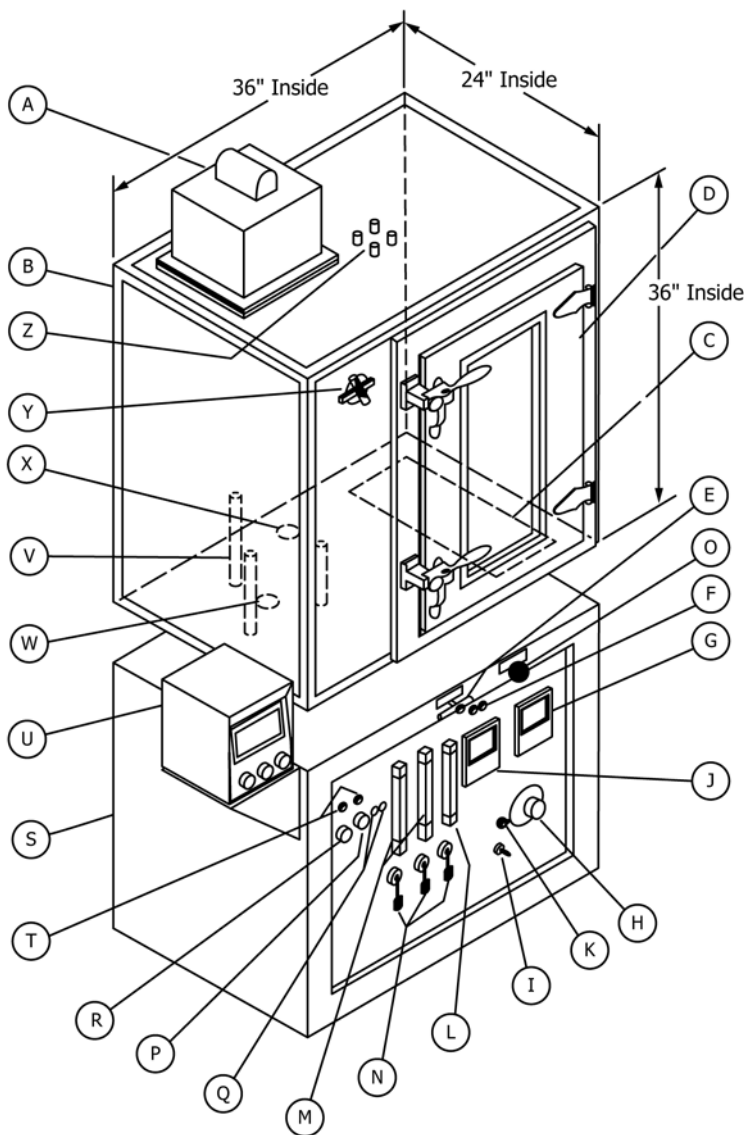

- | | |
|--|-------------------------------------|
| A—Photomultiplier tube housing | N—Flowmeter shutoff valves |
| B—Chamber | O—Sample mover knob |
| C—Blow-out panel (in floor of chamber) | P—Light source switch |
| D—Hinged door with window | Q—Light source voltage jacks |
| E—Exhaust vent control | R—Line switch |
| F—Radiometer output jacks | S—Base cabinet |
| G—Temperature (wall) indicator | T—Indicating lamps |
| H—Autotransformer | U—Microphotometer (photomultiplier) |
| I—Furnace switch | V—Optical system rods |
| J—Voltmeter (furnace) | W—Optical system floor window |
| K—Fuse holder (furnace) | X—Exhaust vent damper |
| L—Radiometer air flowmeter | Y—Inlet vent damper |
| M—Gas and air (burner) flowmeter | Z—Access ports |

FIG. 1 Smoke Density Chamber Assembly

developing and maintaining positive pressure during test periods, in accordance with 11.12. The air-tightness of the chamber shall be tested at least one per test day in accordance with 11.2.

7.1.1.1 If the interior wall surfaces become corroded or the coating starts to peel off, users shall repair the damaged area using any suitable coating material, installed to the coating manufacturer's instructions.